

Operating Instructions

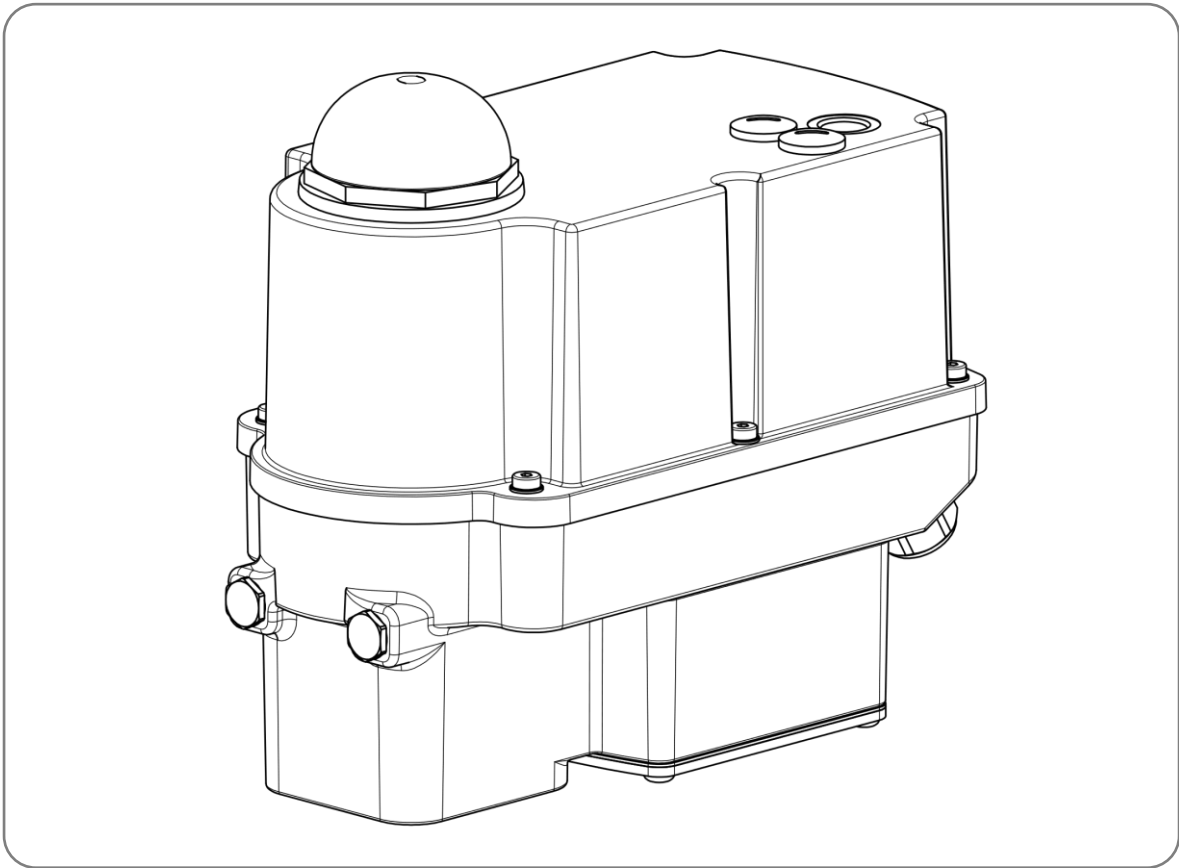

Content

1. Product description.....	3
2. Applicable standards.....	3
3. Key figures.....	4
3.1 Type key	5
4. Symbols used and safety.....	5
5. Intended use	6
5.1 Special conditions	7
6. Storage	7
7. Operating conditions and installation.....	7
8. Manual override and setting of the DIP switches.....	9
8.1 Setting the actuators during commissioning (cover open).....	9
8.2 Setting the actuators during operation (cover closed).....	10
9. Valve mounting.....	11
10. Setting the mechanical end position limiter	11
11. Opening and closing the cover.....	12
12. Adjustment of the position indicator.....	12
13. Electric supply	13
13.1 Safety instructions	13
13.2 Connection diagram.....	14
14. Signalisation and functions	15
14.1 DIP switches	15
14.2 Operating direction.....	16
14.3 Operator push buttons	17
14.4 Status display	18
14.5 Automatic commissioning (see also chapter 14.3).....	18
14.6 Manual commissioning (see also chapter 14.3)	19
14.7 Manual operation (see also chapter 14.3).....	19
15. Operation	20
15.1 Split Range	20
15.2 Valve curve.....	21
16. Commissioning.....	21
17. Maintenance	22
17.1 Cleaning.....	22
17.2 Maintenance	22
17.3 Spare parts	22
17.4 Service address	22
18. Decommissioning and disposal.....	23
19. Annex	23
19.1 Accessories.....	23

1. Product description

The type PSF-Q-***-*-EX actuator is an industrial, multifunctional modulating actuator with fail-safe function for the operation of industrial valves of various types across a wide range of applications. The actuator is designed for assembly with valves and their motor operation.

It is used as an electric valve actuator in hazardous areas of device category II 2G (Ex zone 1, Ex d e, device protection level Gb) or device category II 2D (Ex zone 21, device protection level Db) installed in a fixed position using mounting columns.

An operating status (LED in Ex d motor assembly housing) can be displayed through an inspection glass in the cover. The actuator can be operated by 2 push buttons in the cover (the micro switches for this are likewise located in the Ex d housing).

Programming of the control (DIP switches) is possible in the **safe range** or in a voltage-free state. For this purpose, the cover is detached and the fastening screws in the Ex d housing are removed.

To protect against environmental influences, the cover and lower section are powder-coated.

Conduit entries are available in the lower section of the housing for inserting the electrical cables.

The construction, as well as the interaction of the individual components and the housing regarding their suitability for use in hazardous areas, are tested by PS Automation GmbH and confirmed by the identification with the type label.

The type PSF-Q-***-*-EX actuator essentially consists of:

- the flange
- the plug-in coupling
- the housing section
- the mechanical section (multi-stage spur gear) is located in the lower section of the housing (mounting plate)
- the Ex e/t terminal compartment is located in the upper section of the housing (underneath the cover), this is formed by the cover and the upper side of the lower housing section (mounting plate)
- with conduit entries
- with connection panel for the electrical connections (electrical connection compartment)
- with Ex-d motor control housing

2. Applicable standards

EN IEC 60079-0:2018/General requirements

EN IEC 60079-7:2015/Increased safety "e"

EN 60079-31:2014/Protection by housing "t"

EN 60079-1:2014/Flameproof enclosure "d"

3. Key figures

Certificate number	IECEX TPS 22.0019X
Ex marking	Ex db eb IIC T6 Gb or Ex db eb IIC T4 Gb or rather Ex tb IIIC T80 °C Db or Ex tb IIIC T100 °C Db
Enclosure size	approx. 135 x 245 x 202 mm (BxLxH) (Ex e/Ex t housing)
Actuating power	Depending on variant
Operating time 90° in motor mode	50 Nm variant = 25s / 80 Nm variant = 30s (emergency stop 25s)
Rotation angle	90°
Nominal voltage	24VAC/DC, 100-240VAC
Nominal current	maximum 1,55A AC / 1,1A DC
Backup fuse (only for 100 - 240VAC power supply unit, installed in power supply unit)	2AT 230VAC
External housing material	GD-ALSi9Cu3 (EX eb/tb housing) Die cast
Surface treatment	Powder-coated (s. Marking X)
Ambient temperature range extended	-10 °C ≤ Ta ≤ 40 °C -10 °C ≤ Ta ≤ 60 °C
Temperature class	T6 (at Ta +40 °C) /T4 (at Ta +60 °C)
Max. surface temperature	80 °C (at Ta +40 °C) / 100 °C (at Ta +60 °C)
IP protection class	≥IP64

3.1 Type key

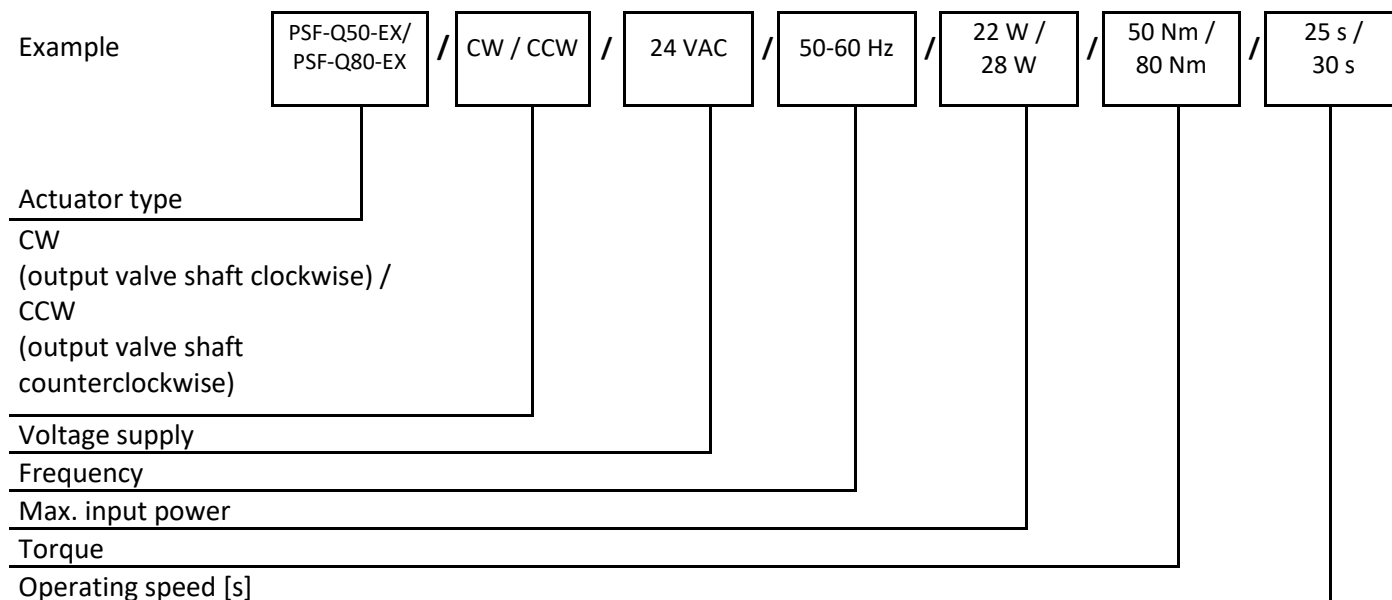

4. Symbols used and safety

General dangers in case of non-observance of the safety instructions

The PSF-Q-EX actuators are built according to the latest state of the art and are operationally safe. Nevertheless, hazards can arise from the actuators if they are not used by trained or at least instructed personnel and/or are used improperly or for purposes other than those for which they are intended.

This threatens, for example

- Danger to life and limb of the user or third parties,
- Dangers to the user's property,
- Impairment of safety and function of the actuator.

It must be ensured that every person in charge of the installation, commissioning, operation, maintenance and repair of the actuators has read and understood these operating instructions and this chapter in particular.

Safety-conscious work

- The actuators may only be operated by trained and authorised operating personnel.
- The safety instructions listed in this manual, the existing national regulations for accident prevention, as well as any internal working, operating and safety instructions of the operator must be observed.
- The isolating procedures specified in the operating instructions must be observed for all work such as installation, commissioning, set-up, operation, changes in operating conditions and operating methods as well as maintenance, inspection and repair.
- Before working on potentially live areas, ensure that they are free of voltage.
- Observe IEC/EN60079-14 when installing the actuators.
- It must be ensured that the actuators are always operated in perfect condition. Externally visible damage and defects, as well as changes in the operating behaviour which may affect safety, must be reported immediately.

Notice of hazards

The following hazard symbols are used in these instructions:



Attention! There are general hazards that can lead to property and/or personal injury.



Caution! Life threatening electrical voltages may be present!



Danger! This symbol warns of an imminent danger to the health of persons. Failure to follow these notices may result in injury.



Attention! Observe handling instructions. Electrostatic sensitive components.

Further instructions

- During maintenance, inspection and repair directly after operation, increased surface temperatures on the motor housing are to be expected. Danger of burns!
- Visible dust deposits must be removed immediately!
- The cover may only be opened in an explosion-free environment! When working in hazardous areas, the European standards EN 60079-14 “Erection of electrical installations in potentially explosive atmospheres” and EN 60079-17 “Testing and maintenance of electrical installations in potentially explosive atmospheres” must be observed.
- When upgrading and operating the actuator with PS accessories, the operating instructions available for them must be observed.
- Connections for the signal inputs and outputs are separated from the circuits that are dangerous to touch by double insulation.

5. Intended use

- The type PSF-Q-EX actuator is a fixed installed device for use in Ex zone 1, 2, 21 or 22. The type PSF-Q-EX actuator is not suitable for use in Zone 0 and Zone 20.
- The electrical data shown on the type plate as well as the device category for the place of use must be observed.
- The operator of an electrical system in a potentially explosive environment must keep the equipment in proper condition, operate it properly, monitor it and carry out maintenance and repair work. See also IEC/EN 60079-17/IEC/EN 60079-19.
- The PSF-Q-EX actuators are constructed exclusively for use as electronic valve actuators. They are designed for assembly with valves and their motorised operation.
- Any use other than this is considered unintended use. The manufacturer is not liable for damage resulting from this.
- The actuators shall not be used outside the limit values cited in the data sheet, catalogue and/or order documentation. Infringement negates all liability on the part of the manufacturer for any resultant damages.
- Proper intended use also includes compliance with the operating, maintenance and repair conditions from the manufacturer.
- Mounting and adjustment of the actuator as well as its maintenance are not considered as intended use. Enhanced safety precautions must be implemented in such situations!

- Assembly/disassembly, operating and maintenance work may only be carried out by suitable skilled personnel familiar with the work. All generally applicable legal regulations and other binding guidelines for work safety, accident prevention and environmental protection must be complied with.
- Unauthorised modifications to the actuators negate all liability on the part of the manufacturer for any resultant damages.

5.1 Special conditions

- To avoid critical electrostatic charges,
 - the devices must not be installed in the vicinity of highly charge-generating processes.
 - the devices are only cleaned with damp or antistatic fabric.
- The length of the flameproof joints is partly larger and the distances of the flameproof joints is partly smaller than the values of table 3 for IIC of EN 60079-1:2014. Information regarding the dimensions of the flameproof joints can be obtained from the manufacturer.
- The fastening screws of flameproof enclosure parts must have a yield strength of at least 640 N/mm².

6. Storage

The following points must be observed for proper storage:

- Store only in well-ventilated, dry rooms.
- Store on a rack, on wooden pallet or similar to protect from ground moisture.
- Cover to protect from dust and dirt.
- Protect actuators from mechanical damage.

7. Operating conditions and installation

- When setting up and operating explosion-protected electrical equipment, care must be taken to ensure protection against harmful environmental influences that restrict the intended use of the equipment. These can be, for example, protection against aggressive liquids or climatic influences. During installation, observe IEC/EN60079-14 and other applicable national standards and regulations at the place of installation.
- The information on the type plate and the applicable documents must be taken into consideration. For cable entries with special installation conditions, (see "X" marking on the cable entry), the relevant instructions given by the manufacturer must be followed.
- The actuators can be operated in the explosion-proof version at ambient temperatures according to the data sheet.
- The duty cycles are according to IEC 60034-1, 8: S2 for short-time duty and S4 for modulating operation (for actuator-specific values, see actuator-specific data sheets).
- For protection against humidity and dust, the actuators are designed according to EN 60529 with protection class IP65.

Installation

- The conductor must be connected carefully at the terminal points so that the individual wires are not damaged. The maximum connection data on the type plate and the applicable documents must be taken into consideration.
- The device must be integrated into a suitable earthing or equipotential bonding system before commissioning, a connection part (4 mm²) is available for this purpose on the underside of the actuator. The effectiveness must be checked before initial commissioning.
- The actuators must be installed with sufficient clearance to remove the cover (Figure 1).
- The mounting position is arbitrary with the exception of “cover downwards” (Figure 2).

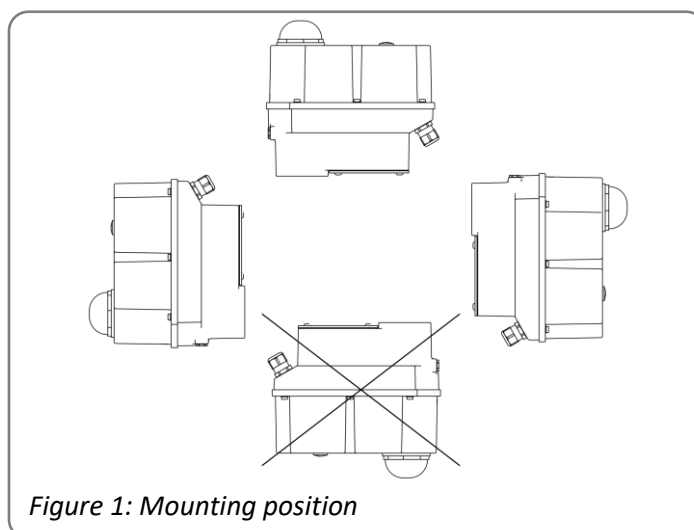
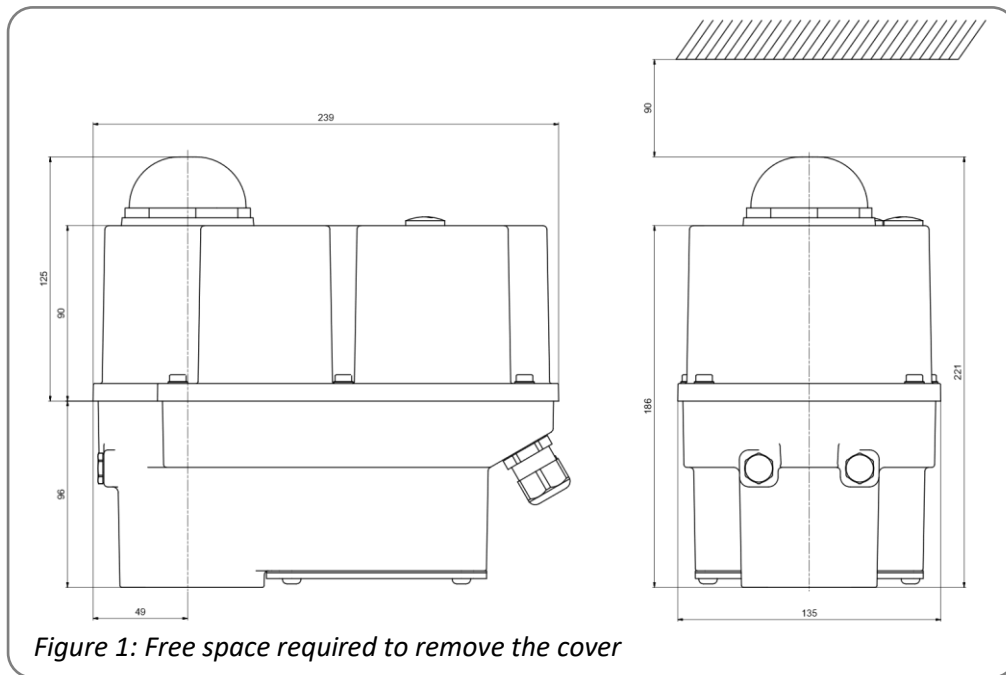

8. Manual override and setting of the DIP switches

8.1 Setting the actuators during commissioning (cover open)

When commissioning the actuators, the cover must be opened. The cover may only be opened in non-hazardous areas and only in a dry environment (see chapter 11 for instructions).

To actuate the actuator during setting work (valve assembly and end position setting), an electrical manual override by means of a push button is available (for operation, see chapter 14.3).

Programming of the control (DIP switch) is possible in voltage-free state (see chapter 14.1). To do this, first loosen 4 fastening screws of the upper cover of the Ex d control housing, then the upper cover can be removed from the Ex d control housing. The upper cover of the Ex d control housing must not be damaged in the area of the joint gap when removing it.

The top cover of the Ex d control housing must be installed considering the position of the push button and the light guide (see figure 3). The tightening torque for the Ex d cover screws is **6 Nm, minimum quality of the screws 8.8. (corrosion resistant)**.

The operating status (status display LED in the Ex d control housing) is indicated by a light guide in the Ex housing (see chapter 14.4).

The electrical connection of the actuators is made via the terminal strip. The wiring diagram must be observed (see chapter 13.2).

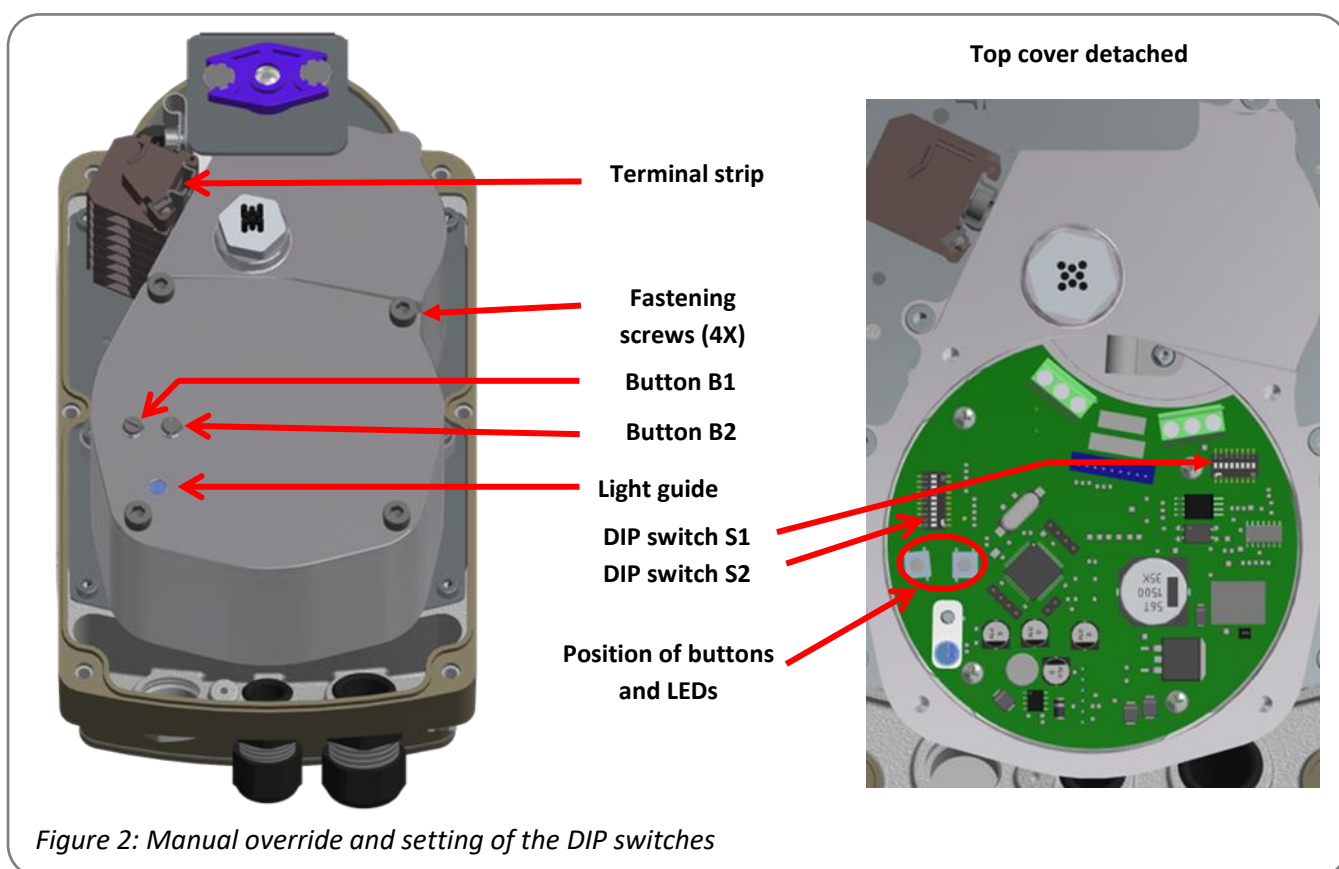

8.2 Setting the actuators during operation (cover closed)

To actuate the actuator during setting work in potentially explosive atmospheres (end position setting), an electrical manual override by means of a push button is provided in the cover (for conditions see chapter 14.3).

To reach the manual override, the screw plugs must be opened.

An operating status (LED in Ex d control housing) can be displayed through an inspection glass in the cover (see figure 4 and chapter 14.4).

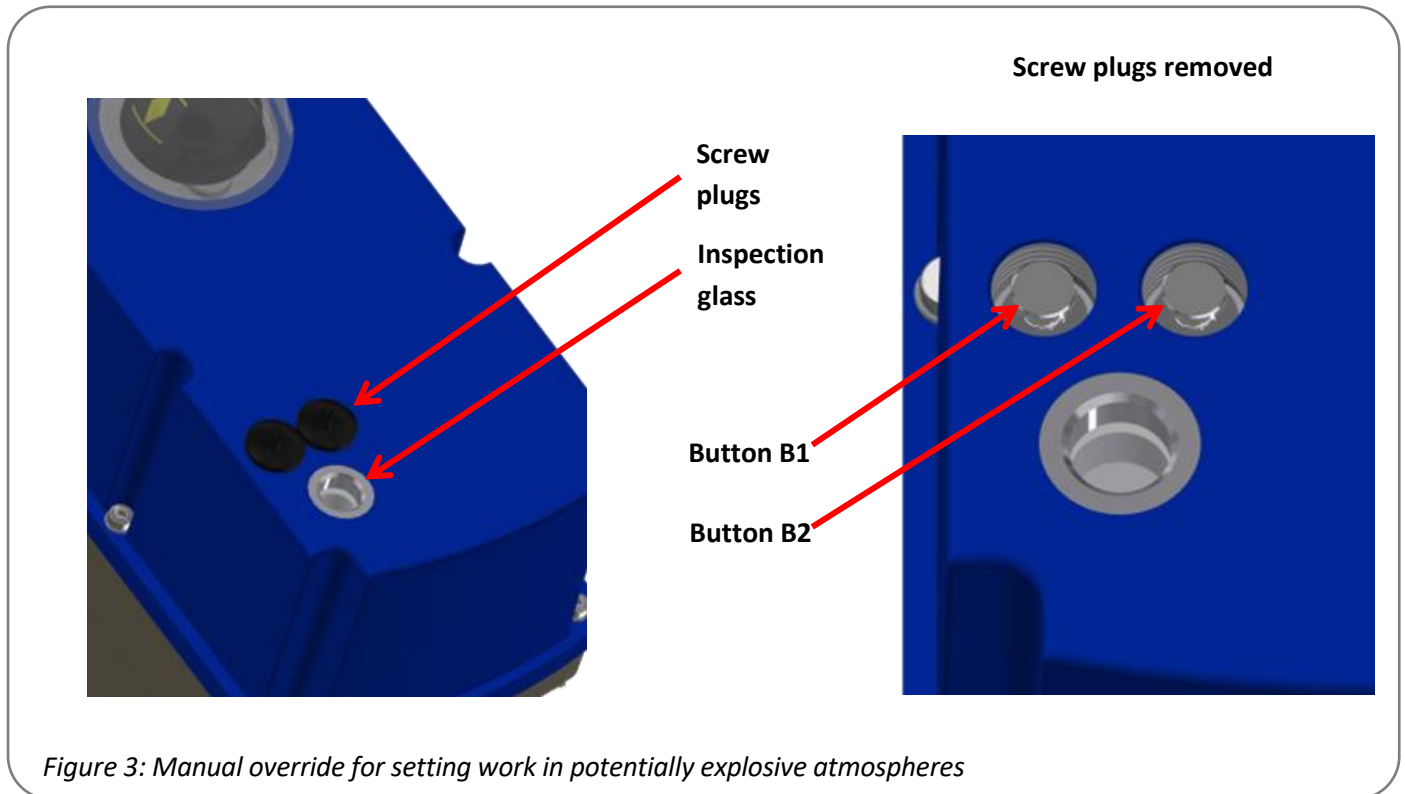
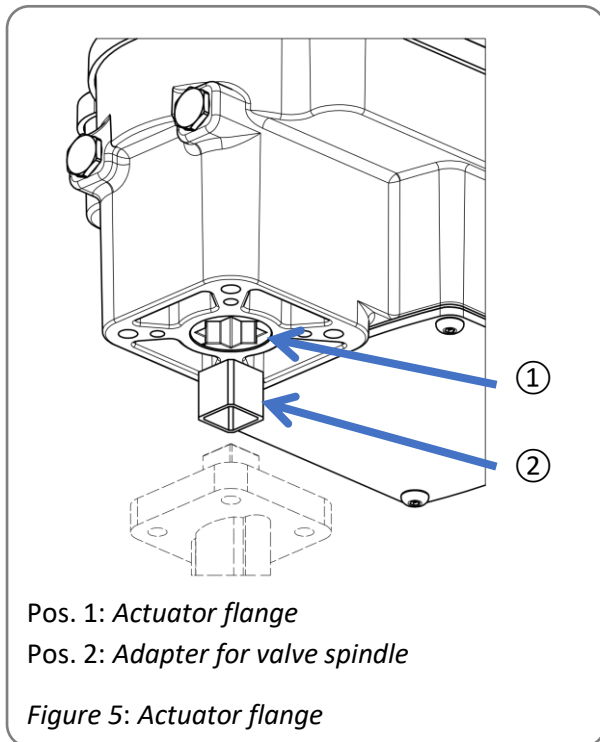

Figure 3: Manual override for setting work in potentially explosive atmospheres

9. Valve mounting

The PSF-Q-EX actuators are designed with a mechanical interface according to ISO 5211 for valve mounting. The gear contains an exchangeable drive bush to connect the actuator to the valve shaft.



- Check if the actuator flange suits the valve flange.
- Check whether the plug-in coupling of the actuator matches the design of the valve shaft. If necessary, commercially available adapters can be used to adapt to the valve shaft.
- Connect the actuator electrically (see 13.).
- Position the actuator by means of manual operation (see 14.7) so that it matches the position of the valve.
- Clean the surface of the connection components, lubricate valve shaft slightly.
- Tighten the screws in a diagonal sequence according to the required torque.

10. Setting the mechanical end position limiter

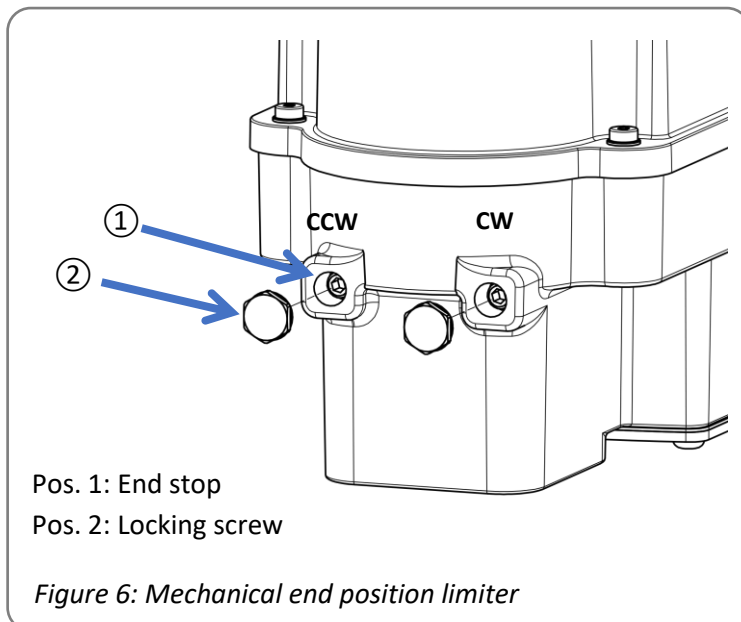

Two adjustable mechanical end stops are available to limit the drive swivel angle.

To do this, first loosen the locking screws and adjust the end stops underneath. Then refit the locking screws, tightening torque 2 Nm.

If the end stops are unscrewed too far, the operator may no longer be able to be operated. In this case, screw the stops further in again.



Do not screw the end stop screws fully into the housing.

11. Opening and closing the cover



The cover may only be opened in non-hazardous areas and only in a dry environment.



Take appropriate ESD handling precautions before opening the housing:

- Earth the actuator.
- Touch earthed housing parts before opening the cover.

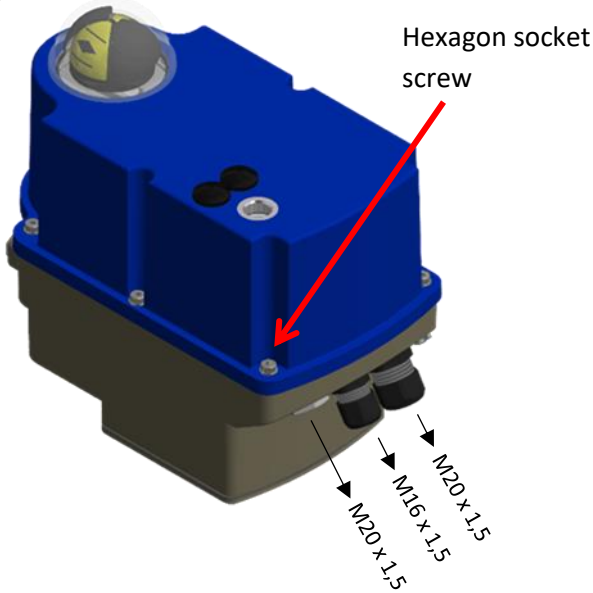

Figure 7: Opening and closing the cover

Opening:

First loosen all screws with a suitable screwdriver, then unscrew them completely from the gearbox housing. The screws are loss-proof. Remove the cover carefully so as not to damage the seal.

Closing:

Place the cover on the gearbox housing and press lightly. Lightly tighten all the screws, then tighten them crosswise. It must be ensured that all screws are firmly tightened to guarantee protection against ingress of water and dust in accordance with EN 60529 to IP65. **The tightening torque for the Ex e/t cover is 3 Nm.**

12. Adjustment of the position indicator

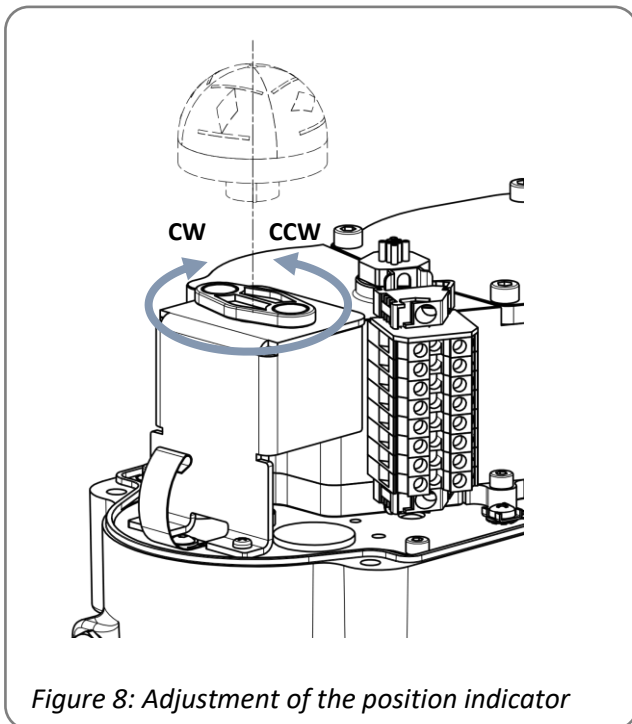

Figure 8: Adjustment of the position indicator

With the cover removed, the magnet holder can be turned by hand to adjust the position indicator. To do this, loosen the grub screw in the magnet holder and tighten it again after adjustment.

The dome on the cover can be adjusted using a size 60 open-end wrench.

13. Electric supply

13.1 Safety instructions



During the connection of the mains voltage, this must be disconnected and secured against unintended reactivation.

The actuator cover must be opened for the electrical connection (see chapter 11).

The mains connection cables must be designed for the nominal current of the actuator.

Yellow-green coloured wiring shall be used **only** for connecting the protective earth connections.

The cable entry options (cable glands) on the actuator side are located on the lower part of the housing.

For this purpose,

- 1x M20 x 1,5 cable gland
- 1x M16 x 1.5 cable gland
- 1x M20 x 1.5 (closed, optional)

are available for feeding through the cables from the outside to the inside (see chapter 11).

When guiding the cables through the cable glands, take the maximum bending radius of the cables into account.

Unused entries must be closed by suitable blanking elements.

As the PSF-Q-EX electrical actuators do not have an internal electrical disconnect device available, a switch or circuit breaker must be provided in the building installation. This must be located in the vicinity of the device, easily accessible to the operator and must be identified as a disconnect device for the device.

Furthermore, the building installation must provide over-current protection devices according to IEC 60364-4-41 for the connection of actuators of protection class I or protection class III at 24 VAC / 24 VDC.

The connection to the terminal block is specified by the manufacturer. The stripping length of the cables is 8 mm and the tightening torque on the terminal block must be min. 0.6 Nm and max. 0.8 Nm.

When closing the cover, make sure that no cables are crushed between the housing and the cover.

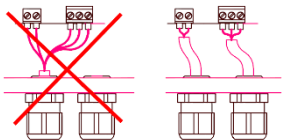

All mains connection lines and control lines must be mechanically secured ahead of the terminals with suitable measures to prevent unintentional loosening.

Mains connection lines and control lines shall not be routed together in one line but rather two separated lines shall be used in all situations!

13.2 Connection diagram

Figure 9 shows the electrical connection for standard drives. The wiring diagram in the actuator is binding for the connection. For the connection of optional accessories, please refer to the respective operating instructions.

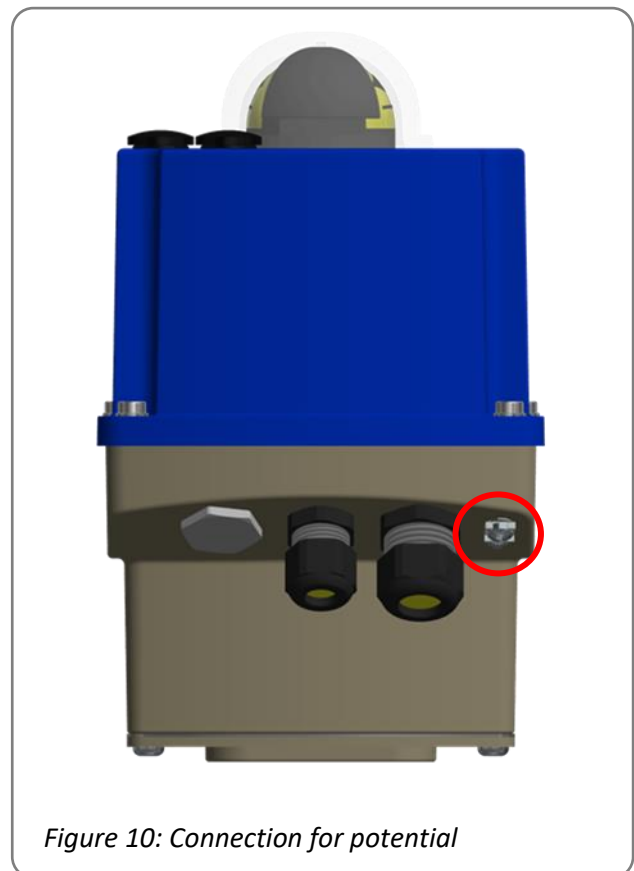
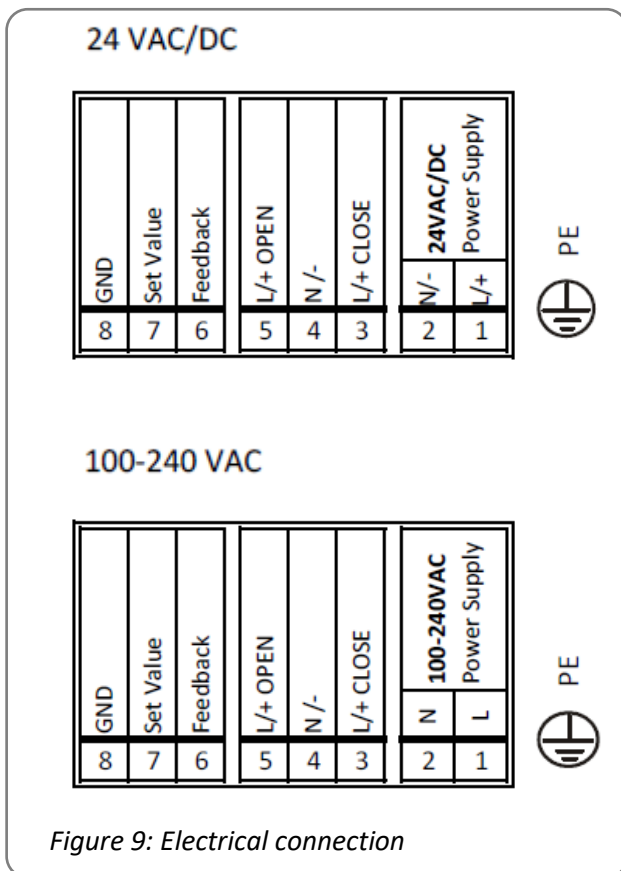

PE earth connection has to be connected to gear casing at  !

The connection for equipotential bonding is made at the external equipotential bonding connection of the actuator.

Ensure that all connecting cables are stripped to the correct length so that they are protected against electric shock.

14. Signalisation and functions

14.1 DIP switches

S1	1	2	3	4	5	6	7	8
Signal	Set Value				Position feedback			
Voltage	On	On	Off	Off	Off	On	Off	On
Current	Off	Off	On	On	On	Off	On	Off

S2		1	2	3 ¹⁾	4 ¹⁾	5	6	7	8	9 ¹⁾	10
Function											
Control via set value							On				
Control via binary inputs							Off				
Output valve shaft counterclockwise (CCW) with increasing set value						On					
Output valve shaft clockwise (CW) with increasing set value						Off					
Automatic Commissioning	Close with torque / Open with torque			On	On					Off	
	Close with torque / Open with travel ²⁾			On	On					On	
Manual commissioning	Close with torque / Open with required rotation angle			On	On					On	
Set value range: 0-10 V / 0-20 mA			On					On	On		
Set value range: 2-10 V / 4-20 mA			Off					On	On		
Set value / Split-Range 5-10 V/10-20 mA			On					On	Off		
Set value / Split-Range 6-10 V/12-20 mA			Off					On	Off		
Set value / Split-Range 0-5 V/0-10 mA			On					Off	On		
Set value / Split-Range 2-6 V/4-12 mA			Off					Off	On		
Torque end position with counterclockwise rotating valve shaft (CCW)		On									
Torque end position with clockwise rotating valve shaft (CW)		Off									
Valve curve LINEAR setpoint/position											Off
Valve curve QUICK OPENING Setpoint/position											On

¹⁾ After changing the switches S2-3, S2-4 and S2-9, perform re-calibration to activate the new operating mode!

²⁾ The position will be defined by torque during commissioning. During operation the actuator will stop at the found position (see 14.5).

14.2 Operating direction

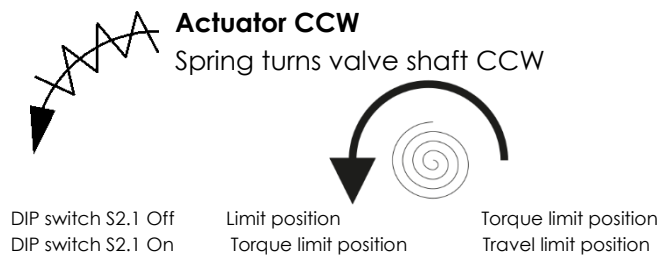
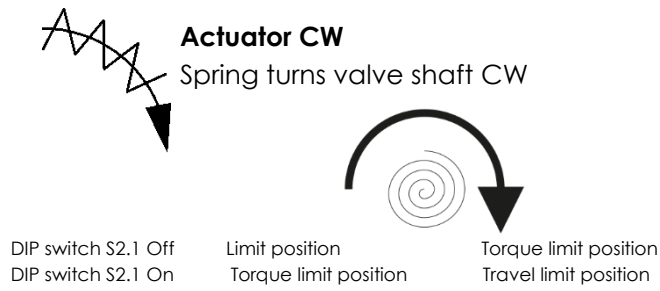

Clockwise (CW) = Spring drives output valve shaft clockwise

Counter Clockwise (CCW) = Spring drives output valve shaft counterclockwise

Figure 11: Operating

14.3 Operator push buttons

Function	Action	Push button B1	Push button B2	LED sequence
Manual Operation	Activate	> Push 3 seconds	> Push 3 seconds	Both LEDs are flashing alternately
	Output valve shaft clockwise (CW)	Push		Green LED is flashing
	Output valve shaft counterclockwise (CCW)		Push	Red LED is flashing
	Stop			Both LEDs are flashing alternately
	Exit	> Push 3 seconds	> Push 3 seconds	Red or green LED is on
Automatic commissioning	Start		> Push 7 seconds	Both LEDs are on
	Commissioning finished			Green LED is flashing 7x (if commissioning is finished), green LED is flashing quickly (if commissioning failed)
	Exit	Push 1 x		Red or green LED is on
Manual commissioning	Activate	> Push 7 seconds		Both LEDs are flashing alternately
	output valve shaft clockwise (CW)	Push		Green LED is flashing
	output valve shaft counterclockwise (CCW)		Push	Red LED is flashing
	Start	> Push 3 seconds	> Push 3 seconds	Both LEDs are on
	Exit	Push 1 x		Red or green LED is on

14.4 Status display

	Green LED	Red LED
Actuator not commissioned	Off	Is flashing quickly
Normal operation / Actuator running	On	Off
Normal operation / Actuator stationary	Off	On
Manual mode active	Is flashing alternately	Is flashing alternately
Manual mode: output valve shaft counterclockwise (CCW)	Off	Is flashing
Manual mode: output valve shaft clockwise (CW)	Is flashing	Off
Automatic commissioning running	On	On
Automatic and manual commissioning successful	Is flashing 7 x – 1.5 seconds off	On
Automatic commissioning failed	Is flashing quickly	On
Overvoltage	Is flashing 1 x – 1.5 seconds off	On
Undervoltage	Is flashing 2 x – 1.5 seconds off	On
Memory error	Is flashing 3 x – 1.5 seconds off	On
Set value error (< 1 V, < 2 mA)	Is flashing 4 x – 1.5 seconds off	On
Torque error	Is flashing 5 x – 1.5 seconds off	On
Under- / overtemperature	Is flashing 6 x – 1.5 seconds off	On

14.5 Automatic commissioning (see also chapter 14.3)

- Ensure secure connection between valve and actuator.
- To start the automatic commissioning push button B2 minimum 7 seconds.
 - Option 1: If adjusted “open with torque – close with torque”, the actuator will drive to the final open valve position via torque, and back to the final closed valve position.
 - Option 2: If adjusted “open with travel”, the actuator will store the open position with the torque end stop (through adjusted end stop screw e.g.) and stop at the saved position during normal operation.
- After successful commissioning, the green LED is flashing 7 times.
- Push button B1 to return to normal operation.
- After successful commissioning, check the determined or set rotation angle by comparing the set value and the valve position.
- In case of unsuccessful commissioning the green LED is flashing quickly. Please check valve mounting.
- For commissioning, it is necessary that a residual rotation angle of at least 2° is available in the end positions before the actuator has reached its mechanical stop.

14.6 Manual commissioning (see also chapter 14.3)

- Ensure secure connection between valve and actuator.
- To activate the individual commissioning push button B1 for minimum 7 seconds.
- For manual operation use push buttons B1 and B2 until the required open valve position is reached.
- Start commissioning of both positions and store them by simultaneously pushing the buttons B1 and B2 for minimum 3 seconds.
- After successful commissioning, the green LED is flashing 7 times.
- Push button B1 to return to normal operation.
- Check the set rotation angle by specifying the setpoint and measuring the actual value.
- In case of unsuccessful commissioning the green LED is flashing quickly.
- For commissioning, it is necessary that a residual rotation angle of at least 2° is available in the end positions before the actuator has reached its mechanical stop.

14.7 Manual operation (see also chapter 14.3)

- Push button B1 and B2 simultaneously for minimum 3 seconds to change to manual operation mode.
- Push button B1 to output valve shaft clockwise (CW).
- Push button B2 to output valve shaft counterclockwise (CCW).
- Push button B1 and B2 simultaneously for minimum 3 seconds to exit from manual operation mode.

15. Operation

The operator of an electrical system in a potentially explosive environment must keep the equipment in proper condition, operate it properly, monitor it and carry out maintenance and repair work. See also IEC/EN 60079-17/IEC/EN 60079-19.

During operation, all internal parameters, such as the required motor torque and the current position, as well as the operating states of the actuator are continuously monitored. This ensures that the actuator is positioned with optimal accuracy and that the valve is always closed correctly.

Cut-off in end positions

Depending on the selected switch position S2-3/4/9, it is determined how the actuator approaches an end position. When selecting "closing/opening with torque", the end position retraction of 3% is active in both directions, in which case switch S2-1 has no function. In the operating modes "opening with swing angle", the actuator remains in the open position that was set during automatic or manual calibration. The end position to be reached by torque is always approached with a retraction of 3%.

15.1 Split Range

With the setting "Set value signal/Split range" switch position S2-2/7/8, the set value is split into a lower or upper range. This means that several actuators can be controlled with only one set value signal.

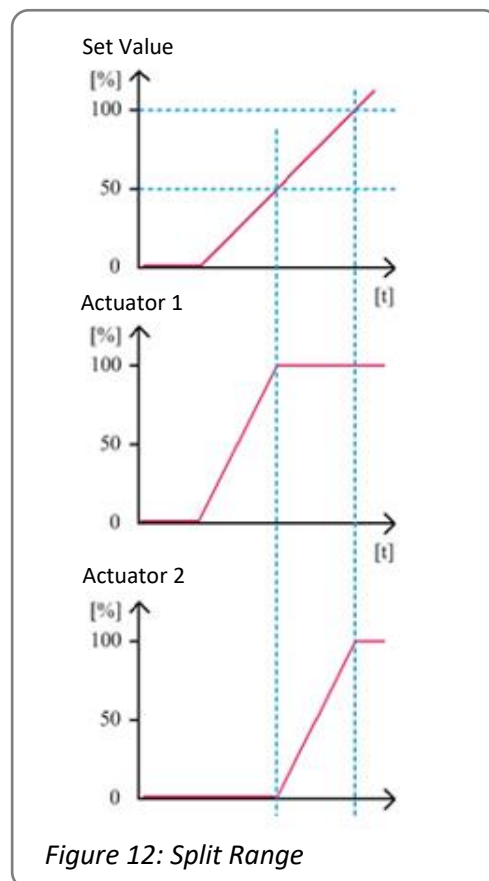

15.2 Valve curve

Switch position S2-10 can be used to select the relationship between the set value and the actuator position. Two curves are available. With the linear valve curve, the actuator position in % corresponds to the set value in %. The "Quick Opening Curve" enables fast valve opening with a small set value.

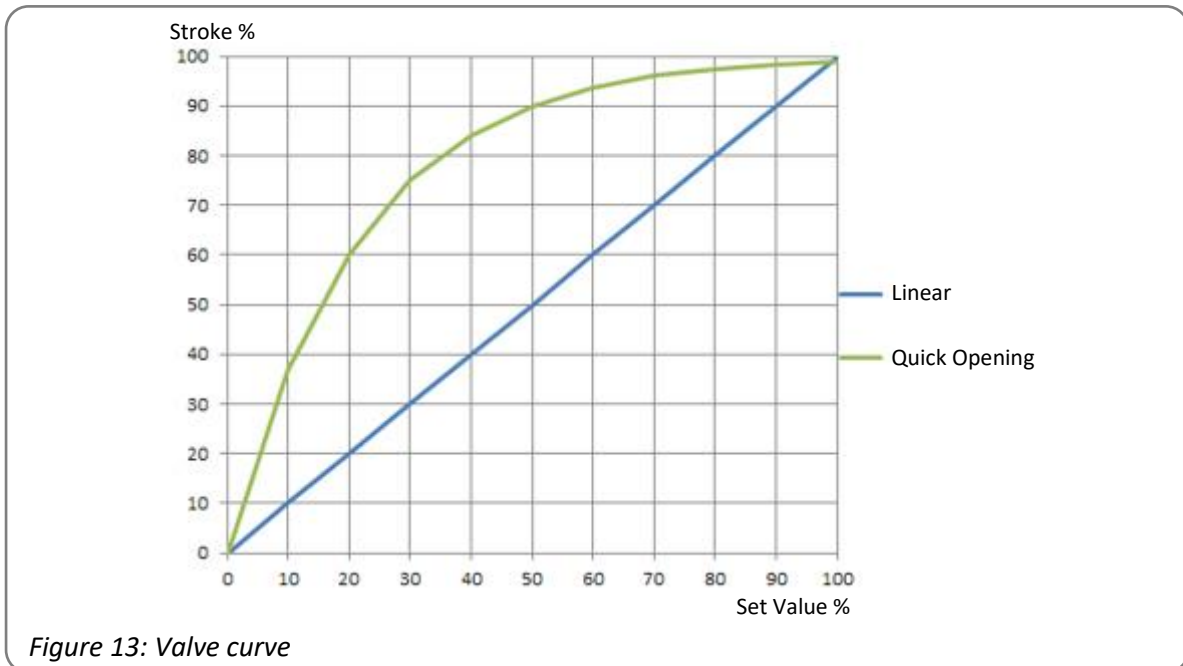

16. Commissioning



- Before initial commissioning, the equipment must be checked for suitability in the relevant zone on the basis of its marking. The values specified on the rating plate and in the applicable documents must not be exceeded.
- Commissioning and use may only be carried out if the equipment is installed within the system in a functional, undamaged and clean condition.
- Open the cover (see 11.), mount the actuator on the valve (see 9.), connect the electric supply (see 13.).
- Perform automatic (see 14.5) or manual commissioning (see 14.6).
- Close the cover. (see 11)



The electrical connection and commissioning with mains voltage applied may only be carried out by trained specialist personnel!

Do not touch any connection lines during commissioning!

17. Maintenance

The actuators are maintenance-free if used under the operating conditions as designated in the data sheet. The gearboxes are lubricated for life and do not require further lubrication.



Caution!

During maintenance and repair the actuator must not be operated electrically.

Personnel carrying out work and maintenance and servicing must be skilled and familiar with the work.

17.1 Cleaning

The actuators should be cleaned dryly. Do not use abrasive cleaning agents or cleaning products containing solvents as the labelling of the safety stickers and the type plate might become illegible. Do not operate the actuator during the cleaning process.

17.2 Maintenance



The actuators have a pre-tensioned spring inside, the gearbox housing **must not** be opened. Defective actuators should be returned to our plant in Bad Duerkheim, Germany, or to our representatives, to be checked for damages and their possible causes. (see 17.4)

17.3 Spare parts

Damaged actuators should be returned to our plant in Bad Duerkheim, Germany, or to our representatives, to be checked for damages and their possible causes. (see 17.4)

17.4 Service address

PS-Automation GmbH
Phillip-Krämer-Ring 13
D-67098 Bad Dürkheim

Tel.: +49 (0) 6322/ 94980-0
E-mail: info@ps-automation.com
www.ps-automation.de

18. Decommissioning and disposal

- Disconnect the mains supply and ensure that it is secured against an accidental switching-on.
- Open the cover.
- Remove external electrical connections.
- Take off the actuator from the valve.

Disposal

For its disposal, the product should be treated as waste containing electrical and electronic equipment and should not be disposed of as household waste.



The actuators have a pre-tensioned spring inside. For disassembly please contact our plant in Bad Duerkheim.



In accordance with 2012/19/EU on waste electrical and electronic equipment (WEEE), the devices described here may not be disposed of via municipal waste disposal companies.

If you are unable or unwilling to arrange for the equipment to be disposed of by a specialist company, you may return the equipment to the manufacturer, who will then ensure that the equipment is disposed of properly for a flat fee.

19. Annex

19.1 Accessories

Various options are available in order to adapt the actuators to the various service conditions. For technical data, please refer to the respective data sheets.

Our representatives:

Italy

PS Automazione S.r.l.
Via Pennella, 94
I-38057 Pergine Valsugana (TN)
Tel.: <+39> 04 61-53 43 67
Fax: <+39> 04 61-50 48 62
E-mail: info@ps-automazione.it

India

PS Automation India Pvt. Ltd.
Srv. No. 25/1, Narhe Industrial Area,
A.P. Narhegaon, Tal. Haveli, Dist.
IND-411041 Pune
Tel.: <+ 91> 20 25 47 39 66
Fax : <+ 91> 20 25 47 39 66
E-mail : sales@ps-automation.in
www.ps-automation.in

Please note to scan the QR codes within an Ex-atmosphere only with a suitable end device!

To find out more about all our sales partners and subsidiaries please scan the QR code below or visit our website:

<https://www.ps-automation.com/locations/?lang=en>



PS Automation GmbH

Philipp-Krämer-Ring 13
D-67098 Bad Dürkheim

Phone: +49 (0) 6322 94980 – 0
E-mail: info@ps-automation.com
www.ps-automation.com

